

## EVALUATION OF THE EARTH PRESSURES IN BACKFILLED STOPES USING LIMIT EQUILIBRIUM ANALYSIS

Michael James, École Polytechnique, Canada  
Li Li, École Polytechnique, Canada  
Michel Aubertin, École Polytechnique, Canada

### ABSTRACT

The backfilling of mine stopes with tailings-cement mixtures, known as paste backfill, has become a common practice throughout the mining industry. Backfilling was initially used to enhance ground stability and is now frequently used as an alternative to tailings surface disposal as well. Knowledge of the stresses imposed by backfill on the walls of stopes is essential for ground stability analysis and for predicting the hydro-geotechnical response of the fill material. Existing analytical solutions for the pressures in backfilled stopes are only applicable to (sub)vertical stopes. This paper presents an analytical solution based on limit equilibrium theory and which is applicable to vertical and inclined stopes. The proposed solution is compared with the results of numerical modelling and with other existing analytical solutions.

### RÉSUMÉ

Le remblayage de chantiers souterrains avec un mélange de résidus miniers cimentés, appelé remblai en pâte, est devenu une pratique courante dans l'industrie minière. Initialement utilisée pour améliorer le contrôle du terrain autour des chantiers, cette technique est maintenant fréquemment considérée comme une alternative à l'entreposage des résidus miniers en surface. La connaissance des contraintes induites par le remblai sur les parois des chantiers est essentielle à l'analyse de stabilité du massif, et pour prédire la réponse hydro-géotechnique du remblai. Les solutions analytiques existantes pour évaluer l'état des contraintes ne sont applicables que pour les chantiers (sub)-verticaux. Dans cet article, une solution analytique basée sur les notions d'équilibre limite est proposée. Elle devient alors applicable aux cas où les chantiers sont verticaux ou inclinés. La solution proposée est comparée avec des résultats de modélisations numériques et avec des solutions analytiques existantes.

### 1. INTRODUCTION

The backfilling of mine stopes with paste backfill, a tailings-cement mixture, is becoming very common throughout the mining industry. Backfilling was initially used to enhance ground stability, but it is now frequently used as an alternative to surface disposal of tailings (Aubertin et al. 2002). Knowledge of the stresses imposed by backfill on the walls of stopes is essential for ground stability analysis. It is also required to predict how the backfill will behave in situ, in terms of the mechanical response to various loading conditions (such as in the occurrence of rock-bursts or blasting vibrations), and of its hydro-geotechnical evolution (which may depend on the local stress state).

Analytical solutions provide a valuable addition to the tools available to estimate the stress state in and around backfilled stopes. They complement numerical methods, which can incorporate more advanced constitutive models for the backfill and surrounding rock mass and can include complementary effects such as the consolidation of the backfill and convergence of the walls. They can thus offer more representative solutions than analytical methods, but they are more costly and time consuming to use. Analytical methods offer a complementary approach,

being cost-effective and practical for many engineering applications (at least in the preliminary phase of a project).

Existing analytical solutions for the pressures in backfilled stopes are only applicable to nearly vertical stopes. This paper presents an analytical solution based on limit equilibrium and which is applicable to vertical and inclined stopes.

### 2. ALTERNATIVE ANALYTICAL METHOD

#### 2.1 Description and main equations

The proposed method is based on Rankine's theory of plastic equilibrium and Coulomb's theory of earth pressure on retaining walls. It can be applied to backfill conditions consistent with active, at-rest or passive conditions.

A soil mass in a state of plastic equilibrium can be considered to be in a state of imminent failure. Potential failure planes within the mass occur at an angle,  $\theta$ , from the horizontal (Terzaghi et al. 1996).

\* Corresponding author: : michel.aubertin@polymtl.ca; tel 514-340-4711 ext. 4046; fax: 514-340 4477.

For a cohesionless soil with an internal friction angle of  $\phi$  under active conditions the angle of the potential failure planes can be calculated using:

$$\theta = \theta_A = 45^\circ + \frac{\phi}{2} \quad [1]$$

For passive conditions, the angle of the potential failure planes is:

$$\theta = \theta_P = 45^\circ - \frac{\phi}{2} \quad [2]$$

The at-rest condition is considered a special case of the active condition and will be discussed later.

Given the assumption of an active or passive state, any number of potential failure surfaces can be assumed to exist within the backfill and each failure surface evaluated based on limit equilibrium. The potential failure surfaces in the active and passive conditions are actually curved; however, Coulomb's theory assumes that the failure surfaces are planar and the error associated with this assumption is reported to be quite small (Terzaghi et al. 1996). Figure 1 is an example of a slope of backfilled height,  $H$ , width,  $D$ , and inclination,  $\alpha$ , in which  $n$  failure surfaces have been assumed on both the hanging wall and the foot wall of the slope.

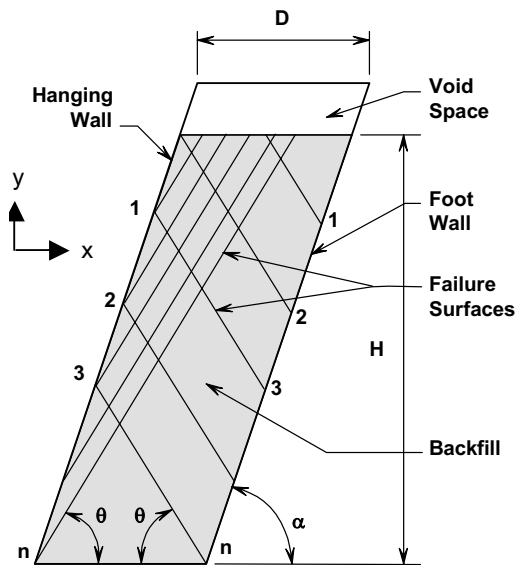

Figure 1 – Schematic of backfilled slope with assumed failure surfaces in backfill.

Figure 2 shows the application of limit equilibrium to a potential failure surface emanating from the foot wall for the active case where the surface does not intersect the opposite wall.  $W_i$  is the weight of the backfill on failure surface  $i$ ,  $P_i$  is the normal force of the backfill on the wall,  $F_i$  is the shear force between the backfill and the wall,  $N_i$  is

the normal force on the failure surface, and  $T_i$  is the shear force developed within the backfill along the failure surface.

Rankine's earth pressure theory assumes that the friction on the potential failure plane is fully developed (Terzaghi et al. 1996) and Coulomb's theory assumes that the friction at the interface between the backfill and the wall is also fully developed (Terzaghi et al. 1996); thus:

$$T_i = N_i \cdot \tan \phi \quad [3]$$

$$F_i = P_i \cdot \tan \delta \quad [4]$$

Where  $\delta$  is the friction angle between the backfill and the wall; it cannot be greater than  $\phi$ .

The equations of equilibrium for the active case on the foot wall when the failure surface does not intersect the hanging wall are:

$$\begin{aligned} \Sigma F_x &= N_i \cdot \sin \theta - T_i \cdot \cos \theta \\ &- P_{FOOT,i} \cdot \sin \alpha + F_i \cdot \cos \alpha = 0 \end{aligned} \quad [5]$$

$$\begin{aligned} \Sigma F_y &= P_{FOOT,i} \cdot \cos \alpha + N_i \cdot \cos \theta \\ &+ F_i \cdot \sin \alpha + T_i \cdot \sin \theta - W_i = 0 \end{aligned} \quad [6]$$

Solving Equations 5 and 6 gives the normal load on the foot wall:

$$P_{FOOT,i} = \frac{\cos \delta \cdot \sin(\theta - \phi)}{\sin(\alpha + \theta - \delta - \phi)} W_i \quad [7]$$

When the failure surface intersects the hanging wall, as shown on Figure 3, the equations of equilibrium must include forces on the hanging wall above the point of intersection. The resulting normal load on the foot wall can be estimated using:

$$\begin{aligned} P_{FOOT,i} &= \frac{\cos \delta}{\sin(\alpha + \theta - \delta - \phi)} \cdot \\ &\left\{ W_i \cdot \sin(\theta - \phi) + W^* \cdot \frac{\sin(\alpha + \delta)}{\sin(\alpha + \phi + \delta - \theta)} \right\} \end{aligned} \quad [8]$$

Where  $W^*$  is the weight of backfill on the failure surface projected from the hanging wall.

The equations for the hanging wall in the active case when the failure surface does not intersect the foot wall are:

$$\begin{aligned} \Sigma F_x &= P_{HANG,i} \cdot \sin \alpha + F_i \cdot \cos \alpha \\ - N_i \cdot \sin \theta + T_i \cdot \cos \theta &= 0 \end{aligned} \quad [9]$$

$$\begin{aligned} \Sigma F_y &= -P_{HANG,i} \cdot \cos \alpha + F_i \cdot \sin \alpha \\ + N_i \cdot \cos \theta + T_i \cdot \sin \theta - W_i &= 0 \end{aligned} \quad [10]$$

Solving gives:

$$P_{HANG,i} = \frac{\cos \delta \cdot \sin(\theta - \phi)}{\sin(\alpha + \phi + \delta - \theta)} W_i \quad [11]$$

When the failure surface from the hanging wall intersects the foot wall, the following equation is used:

$$\begin{aligned} P_{HANG,i} &= \frac{-\cos \delta \cdot \sin(\phi - \theta)}{\sin(\alpha + \phi + \delta - \theta)} \cdot \\ \left\{ W_i + \frac{2 \cdot \sin(\alpha - \delta) \cdot \cos(\phi - \theta)}{\sin(\alpha + \theta - \delta - \phi)} W^* \right\} \end{aligned} \quad [12]$$

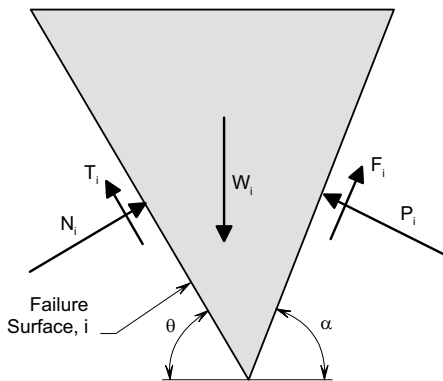

Figure 2 – Forces on backfill wedge defined by failure surface, i.

The assumptions of full development of the shear strength within the backfill and of the frictional resistance between the backfill and the wall may result in an over-estimation of the normal and shear stresses on the walls in the some areas, particularly in the upper portion of the stope, and thus may over-estimate the stress transfer and arching effect (Li et al. 2003). However, it is expected that the influence of the assumption tends to decrease with increasing height of backfill.

A solution for each failure surface is obtained using the above equations for both walls of the stope. Due to the interaction of the opposing walls, the solution is conducted downwards, from the top to the bottom, while alternating between the walls. For each failure surface, the normal

and shear stresses on the wall,  $p_i$  and  $f_i$ , can be calculated using Equations 13 and 14.

$$p_i = \frac{P_i - P_{i-1}}{t_i} \quad [13]$$

$$f_i = \frac{F_i - F_{i-1}}{t_i} \quad [14]$$

Where  $t_i$  is the distance between failure surface  $i$  and failure surface  $i-1$ .

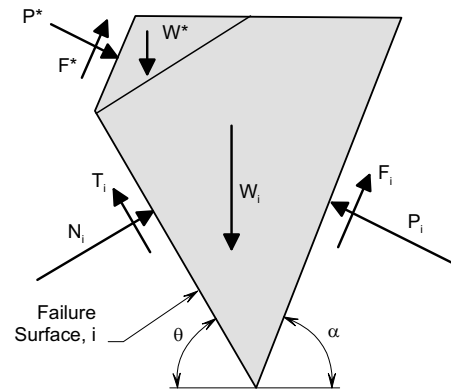

Figure 3 – Forces on backfill wedge defined by failure surface, i, when opposite wall is intersected.

## 2.2 The Reaction State of the Backfill

The ultimate state of the backfill within a stope depends on the movement of the walls which at relatively low levels of stress in the rock mass may be influenced by the stresses induced by the backfill. In general, if the convergence of the walls is complete by the time of backfill placement, the backfill will assume an at-rest state. If the walls undergo significant convergence after placement of the backfill, the backfill would assume a passive state, and in the unlikely event that the pressures induced by the backfill are sufficient to cause the walls to open (diverge), the backfill would assume an active state.

Based on studies of retaining walls, lateral movement away from the backfill of 0.001 to 0.004 H is sufficient to cause the state of cohesionless backfill to become active (Bowles 1996). Development of the passive state typically requires lateral movement towards the backfill of 0.01 to 0.04 H for cohesionless material.

As mentioned earlier, the at-rest condition can be considered a special case of the active condition which allows application of the Rankine theory. Based on Rankine's theory, the coefficient of active earth pressure,  $K_A$ , can be determined using:

$$K_A = \tan^2 \left( 45^\circ - \frac{\phi}{2} \right) \quad [15]$$

The coefficient of at-rest earth pressure,  $K_0$ , is generally determined using Equation 16 which is empirical (Bowles, 1996).

$$K_0 = 1 - \sin \phi \quad [16]$$

Assuming that the stresses within a soil mass in an active condition are proportionally greater than those in an at-rest condition, and that the ratio of the active to at-rest stresses is equal to  $K_A/K_0$ , then it is possible to apply Rankine's theory of plastic equilibrium to an at-rest soil mass by using a reduced or apparent friction angle,  $\phi^*$  (James and Julien 2002).

The apparent friction angle can be calculated as follows.

$$K_A^* = K_0 \quad [17]$$

$$\tan^2 \left( 45^\circ - \frac{\phi^*}{2} \right) = 1 - \sin \phi \quad [18]$$

$$\phi^* = -2 \left\{ \tan^{-1} [1 - \sin \phi]^{1/2} - 45^\circ \right\}. \quad [19]$$

For practical purposes  $\phi^*$  can often be assumed to equal 2/3 of  $\phi$  for the typical range of internal friction angles of cohesionless backfills.

The alternative method can be applied to backfill in an at-rest condition through use of the apparent internal friction angle which results in a state of stress within the backfill roughly two-thirds of the ultimate stress assumed by the Rankine theory.

### 3. EXISTING ANALYTICAL METHODS

#### 3.1 The Overburden Method

The overburden method is the simplest and most commonly used method of approximating the state of stress within a backfilled slope. The vertical stress within the backfill,  $\sigma_{vh}$ , at a depth,  $h$ , below the surface of the backfill is simply assumed to equal the weight of the overlying backfill.

$$\sigma_{vh} = \gamma h \quad [20]$$

Where  $\gamma$  is the unit weight of the backfill. The corresponding horizontal stress,  $\sigma_{hh}$ , is typically estimated using a stress ratio,  $K$ , assumed to be equal to the active, passive, or at-rest earth pressure coefficients,  $K_A$ ,  $K_0$  or  $K_P$ , depending on the response of the walls.

$$\sigma_{hh} = K \cdot \sigma_{vh} \quad [21]$$

The overburden method neglects the effects of friction between the backfill and the walls (the cause of the arching effect) and of the proximity of the walls which at a critical distance begins to reduce the length of the failure planes inherently assumed in the use of the earth pressure coefficients. Hence, the overburden method is applicable to wide, smooth-walled, vertical stopes where the shear stress between the backfill and the walls of the stopes becomes negligible.

Another method of estimating the horizontal (elastic) stresses is through use of the Poisson's ratio,  $\nu$ :

$$\sigma_{hh} = \sigma_{vh} \frac{\nu}{1 - \nu} \quad [22]$$

Alternatively, the stress induced by the backfill can be evaluated using the convergence-confinement method, with the characteristic curves of the fill and rock mass response (eg. Hoek and Brown, 1980). This approach neglects the effect of friction along the wall, and thus omits stress redistribution related to arching (e.g. Aubertin et al. 2003).

#### 3.2 The Marston Method

Aubertin et al. (2003) proposed an analytical method of approximating the state of stress within backfilled vertical stopes based on solutions developed by Marston (1930) to calculate the loads on conduits in ditches. The Marston method is based on the equilibrium of horizontal layer elements of the backfill. The vertical stresses within the backfill at position  $h$  can be calculated as (e.g., McCarthy 1988).

$$\sigma_{vh} = \frac{\gamma B}{K} \left[ \frac{1 - \exp\{-2kh / B \cdot \tan \delta\}}{2 \cdot \tan \delta} \right] \quad [23]$$

where  $K$  is the earth pressure coefficient consistent with the assumed state of stress. The horizontal stress is again calculated by:

$$\sigma_{hh} = K \cdot \sigma_{vh} \quad [24]$$

The formulation includes the friction between the backfill and the wall and thus considers an arching effect.

An important restriction of the Marston method is that verticality of the stope is assumed; it can thus only be applied to nearly vertical openings (Aubertin et al. 2003; Li et al. 2003)

### 4. NUMERICAL MODELLING

Numerical modelling potentially offers the most accurate and comprehensive method of calculating the state of

stress within a backfilled slope. With numerical modelling it is possible to consider any geometric configuration for the slope, variation of the properties of the backfill in space and in time, movement of the walls of the slope, and the interaction between the backfill and the walls of the slope and bulkheads or plugs. Numerical models are particularly useful to investigate various scenarios and to study the effects of factors influencing backfill/slope interaction (e.g. Aubertin et al. 2003; Li et al. 2003)

The disadvantages of numerical methods include the specialized skills and tools required and the time and expense involved in completing analyses.

The following sequence was modelled with FLAC-2D (Itasca 2002) in the numerical analyses:

- Instantaneous excavation of the stope;
- Convergence of the walls due to an assumed stress field within the rock; and
- Instantaneous placement of the backfill in a normally consolidated state.

## 5. RESULTS AND COMPARISONS

### 5.1 Narrow, Vertical Stope

Figure 4 is an illustration of a narrow, vertical stope with a width of 6.0 meters and a backfilled height of 45 meters. The assumed properties of the backfill are shown on the figure.

The friction angle between the backfill and the rock,  $\delta$ , is  $30^\circ$ . The stope is assumed to be fully drained with insignificant wall movement. Thus, the backfill is normally consolidated under its own weight and in an at-rest condition.

Figure 5 presents the estimated normal stresses on the walls,  $p$ , of the stope shown in Figure 4 using the Overburden method ( $K=0.5$ ), the Marston method ( $K=0.5$ ), numerical modelling conducted using FLAC (Li et al. 2003), and the proposed alternative method presented above (Eqs. 7, 8 and 11-14). Due to symmetry, the stresses on the foot wall and hanging wall are identical; thus, only the stresses on the foot wall are shown.

The upper portion of the stress distribution estimated by the alternative method is equivalent to the earth pressures calculated using the Coulomb's theory of earth pressure on retaining walls. Once the failure surfaces begin to intersect the opposite wall ( $h = 10$  m), the stresses increase slightly beyond those of Coulomb's theory due to the effect of the opposite wall. However, at some depth ( $h = 18$  m in this case), the stresses attain a maximum value due to the failure surfaces from the opposite wall reaching a maximum length and additional increments of load due to failure surfaces on both walls being constant.

For the case of a backfilled, narrow, vertical stope where the backfill is in an at-rest condition, Marston's method

and the alternative method provide results in good agreement with those of numerical modelling. The overburden method greatly overestimates the normal stress and provides an unrealistic approximation of the stresses.

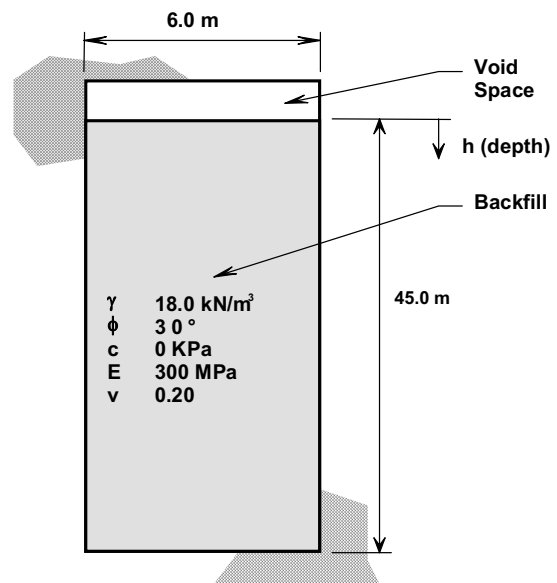

Figure 4 – Schematic of backfilled, narrow, vertical stope.

### 5.2 Narrow, Inclined Stope

In practice a majority of stopes are inclined rather than vertical and neither the Marston method nor the overburden method are applicable to inclined stopes. However, the alternative method and numerical modelling can be applied to inclined stopes. A backfilled, narrow stope with a height of 45 meters, a width of 6 meters and an inclination of  $60^\circ$  is shown on Figure 6.

The properties of the backfill and backfill/wall friction angle are the same as for the vertical stope presented on Figure 4.

The respective normal pressures on the hanging and foot walls of the inclined slope as determined by numerical modelling and the alternative method (Eqs. 7, 8 and 11-14) are presented on Figures 7 and 8. Considering the results of the alternative method, as one would expect, inclination of the stope significantly reduces the normal stress on the hanging wall. The normal stresses on the foot wall are also reduced despite the fact that with increasing inclination the normal stress on the foot wall supports a greater percentage of the backfill weight. The reason for this is that the normal pressure on the hanging wall is much lower and thus has much less influence on the foot wall. This effect is incorporated into the alternative

method through the use of Equation 8 where  $W^*$  decreases with increasing inclination of the stope.

Comparing the results of the proposed method with numerical modelling (Figures 7 and 8), the stresses estimated by the proposed method for the footwall of the inclined stope are in quite good agreement with the results of numerical modelling (Figure 7). The estimated stresses on the hanging wall as estimated by numerical modelling are much greater than those estimated by the proposed method (Figure 8). This is probably due to fact that no interface elements were introduced between the backfill and the walls of the stope in the numerical modelling. Thus, sliding and separation between the backfill and the hanging wall were not allowed. The numerical model modelling results herein have probably over-estimated the stresses on the hanging walls for the case of the inclined stope. Further numerical modelling is thus needed.

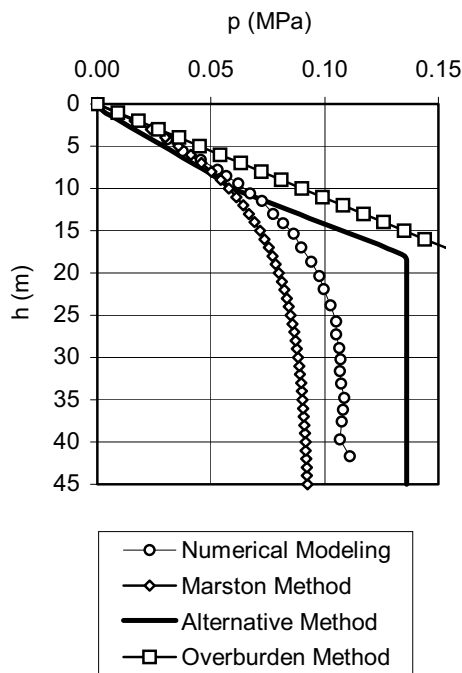

Figure 5 – Normal stress on the walls of a backfilled, narrow, vertical stope.

## 6. DISCUSSION

The proposed alternative method has been developed for cohesionless material but it can readily be adapted to cases where the hanging wall and foot wall have different frictional characteristics and different inclinations, and where the backfill has a cohesive component. As an illustrative example, Figures 9 and 10 show the normal stress on the foot wall and hanging wall, respectively, of the stope illustrated in Figure 6 at various inclinations.

As shown on Figures 9 and 10, the stresses on the foot and hanging walls of inclined stopes are significantly effected by the inclination of the stopes, particularly on the hanging walls. At inclinations of  $70^\circ$  to  $90^\circ$  the stresses on foot walls is essentially unchanged; however, at inclinations less than  $70^\circ$  there is a significant decrease in the stresses. For the hanging walls, there is a progressively greater decrease in the stresses on the walls as the inclination of the stope approaches the inclination of the failure planes.

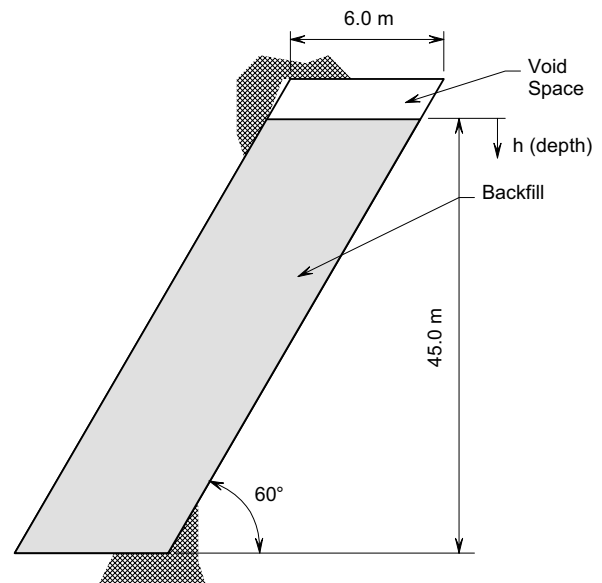

Figure 6 – Schematic of a backfilled, narrow, inclined stope.

## 7. CONCLUDING REMARKS

The alternative method proposed herein is well-suited for solution through the use of spreadsheets, providing cost-effective results, particularly for parametric studies.

As shown, the proposed alternative method provides reasonable approximations of the stresses imposed by backfill on the walls of stopes and therefore can be a useful tool in ground stability analysis. The work presented here is part of an ongoing investigation on the measurement and modelling of stress states in and around backfill stopes. It complements other recent modelling advances made in this area (see also Li et al. 2004; this conference)

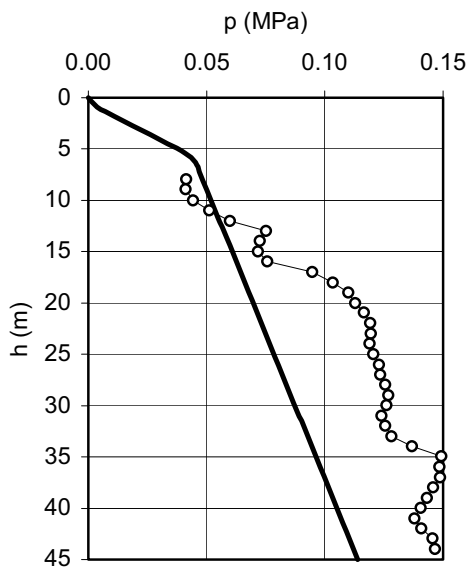

Figure 7 – Normal stress,  $p$ , on the foot wall.

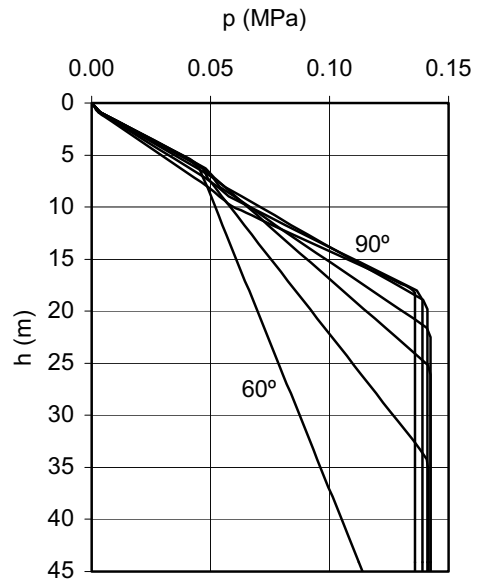

Figure 9 – Normal stress on the foot wall at inclinations of 60 to 90° in 5° increments.

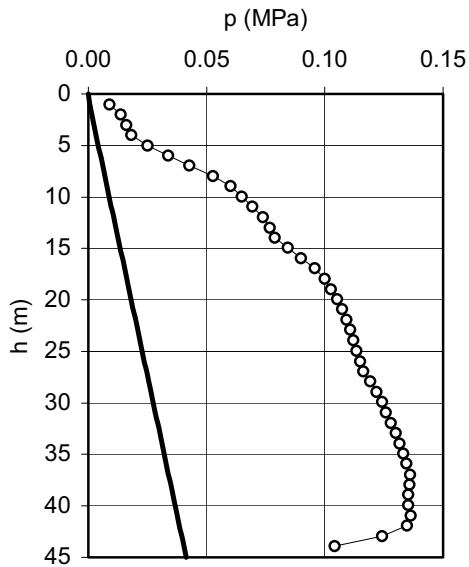

Figure 8 – Normal stress,  $p$ , on the hanging wall.

## 8. ACKNOWLEDGEMENT

The work has been financed in part through grants by the IRSST and by the Industrial NSERC Polytechnique-UQAT Chair (<http://www.polymtl.ca/enviro-geremi/>).

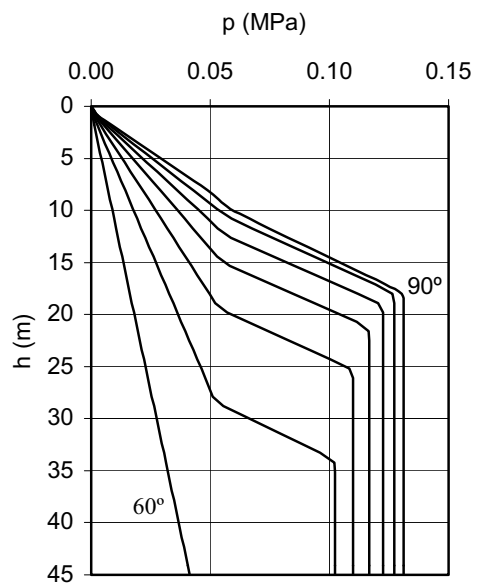

Figure 10 – Normal stress on the hanging wall at inclinations of 60 to 90° in 5° increments.

## 9. REFERENCES

Aubertin, M., Bussi re, B. and Bernier, L. 2002. Environnement et Gestion des Rejets Miniers. Manual on CD-ROM, Presses Internationales Polytechnique.

Aubertin, M., Li, Li, Arnoldi, S., Belem, T., Bussi re, B., Benzaazoua, M., and Simon, R. 2003. Interaction Between Backfill and Rock Mass in Narrow Stopes. In P.J. Culligan, H.H. Einstein and A.J. Whittle (eds), Soil and Rock America 2003, 1:1157-1164. Essen: Verlag Gluckauf Essen (VGE).

Bowles, J. E., 1996. Foundation Analysis and Design, McGraw-Hill Companies Inc.

Hoek, E. and Brown, E.T. 1980. Underground Excavations in Rock. London: Institution of Mining and Metallurgy.

Itasca Consulting Group, Inc. 2002. FLAC – Fast Lagrangian Analysis of Continua, User's Guide. Minneapolis, MN.

James, M. and Julien, M. 2002. Alternative Design Method for the Protection of Underground Mine Openings Using Energy Absorbing Barriers and Free Draining Bulkheads, Proc. Of the 55<sup>th</sup> Canadian Geotechnical Conference, Niagara Falls.

Li, L., Aubertin, M., Simon, R., Bussi re, B. & Belem, T. 2003. Modelling Arching Effects in Narrow Backfilled Stopes with FLAC. FLAC and Numerical Modelling in Geomechanics – 2003, A.A. Balkema Publishers. pp. 211-219.

Li, L., Aubertin, M., Simon, R., Belem, T., Simon, R., James, M., Bussi re, B. 2004. A 3D Analytical Solution for Evaluating Earth Pressures in Vertical Backfilled Stopes. Proceedings of the 56<sup>th</sup> Canadian Geotechnical Conference, Quebec City.

Martson, A. 1930. The theory of external loads on closed conduits in the light of latest experiments. Bulletin No. 96, Iowa Engineering Experiment Station, Ames, Iowa.

McCarthy, D. F. 1988. Essentials of Soil Mechanics and Foundations: Basic Geotechnics. 4<sup>th</sup> edition, Prentice-Hall.

Terzaghi, K., Peck, R. and Mesri, G. 1996. Soil Mechanics in Engineering Practice. John Wiley & Sons Inc., Toronto.